



# Additional Features for MSELV Chassis with sbRIO

Tyler Lemon  
Detector Support Group  
December 18, 2019

# Contents

- Overview
- New features proposed
  - Increased sensor quantity
  - sbRIO breakout RIO Mezzanine Card (RMC)
  - Remote web interface
  - Sensor flexibility
    - Input ports
    - Sensor configurations
  - Direct EPICS communication
- Conclusion

# Overview

- sbRIO successfully implemented in Multi-Sensor Excitation Low Voltage (“MSELV”) chassis
  - Project and status detailed in two previous talks
    - [September 4, 2019 - Hall B Magnets' LV Chassis Improvements](#)
    - [December 4, 2019 - sbRIO-based Upgrade of Hall B Magnets' MSELV Chassis](#)
  - Waiting on delivery of parts to test chassis
- Looking into additions to MSELV chassis that will improve its functionality and make its program transparent to end user

# Increased Sensor Quantity

- Current chassis can support 56 sensors
  - DE0-Nano uses only 32 DIO channels for sensor readout
  - Sensor port quantity on chassis are limited by connector size and chassis size
- sbRIO could support up to 192 total sensors
  - sbRIO has 96 DIO signals
  - With existing chassis readout board, eight DIO signals needed per readout board with 16 sensors per readout board
  - $96 \text{ DIO} \div 8 \frac{\text{DIO}}{\text{board}} \times 16 \frac{\text{sensors}}{\text{board}} = 192 \text{ sensors}$
- Would need to redesign chassis layout to accommodate more readout boards and sensor ports

# sbRIO Breakout RMC

- For development, sbRIO is connected to MSELV chassis by a NI-9694 Digital I/O Breakout RMC wired to a 40-pin socket on the DE0 Breakout board
- New RMC would connect to sbRIO and include power fuses, DIO lines, and line drivers for each readout board in the chassis

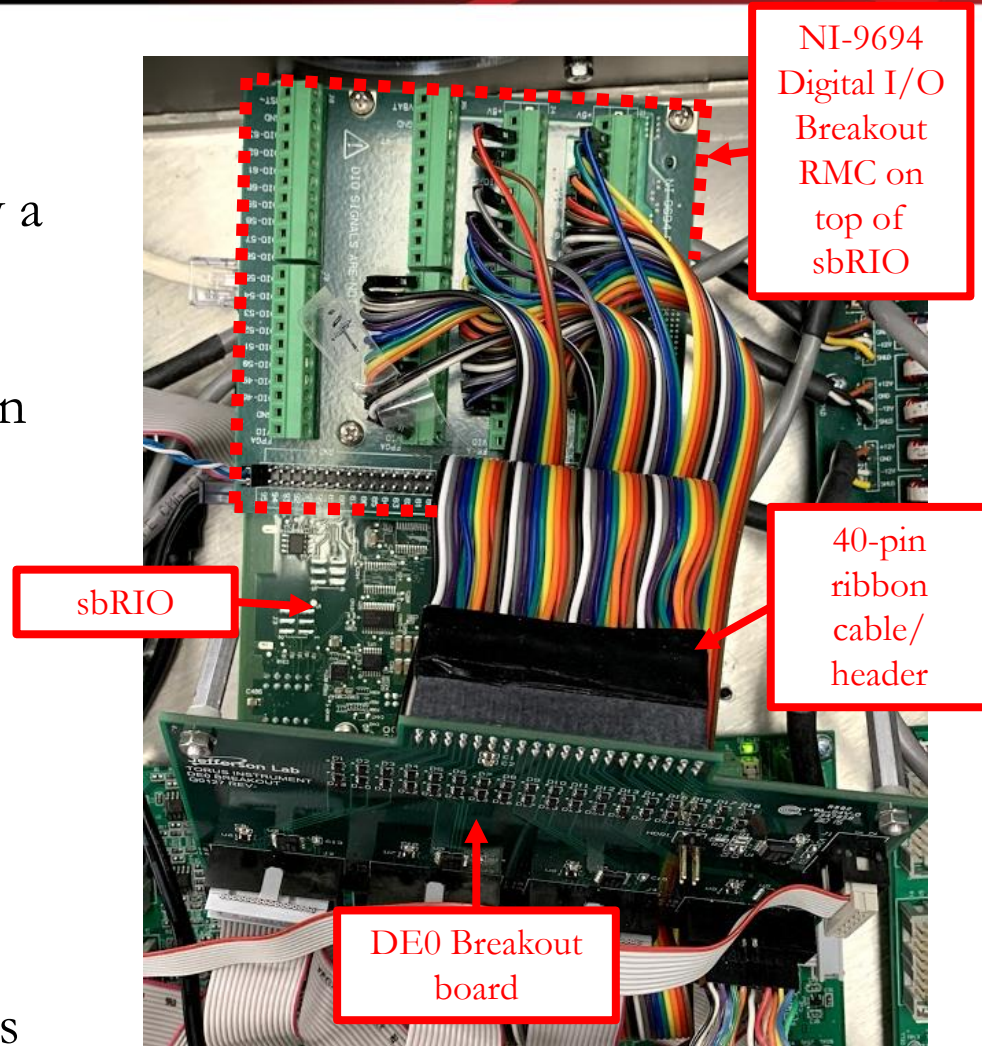

Test set up for sbRIO development in MSELV Chassis.

# Remote Web Interface

- Remote interface to chassis through web browser
  - End user would not need LabVIEW
- Two methods
  - Remote panel server
    - Displays a VI's front panel on sbRIO webserver
    - Not usable due to limited support of required Netscape Plugin Application Programming Interface
  - Web server on sbRIO with HTML and JavaScript interface
    - Displays a customizable HTML page that uses JavaScript to read/write to shared variables in sbRIO program
- Successfully developed and deployed prototype HTML/JavaScript web interface

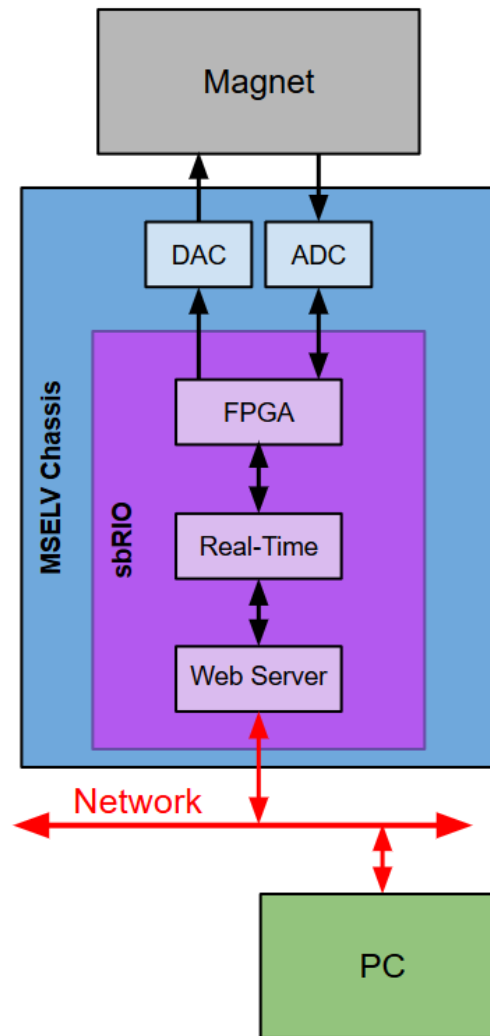

# Remote Web Interface – Monitoring Page

HTML tabs for different pages

sbRIO heartbeat

Cernox		PT100		Load Cell		Strain Gauge		Hall Sensor	
1	325.00	1	36.91	1	512.25	1	2.66e-3	1	3.18e-4
2	325.00	2	33.15	2	349.23	2	1.34e-3		
3	325.00	3	38.47	3	100.59	3	7.90e-4		
4	325.00	4	39.36	4	121.86	4	9.68e-4		
5	325.00	5	34.25	5	0.00e+0	5	1.30e-3		
6	325.00	6	36.13	6	536.18	6	0.10		
7	325.00	7	33.20			7	1.48e-3		
8	325.00	8	41.30			8	1.11e-3		
9	325.00	9	37.69						
10	325.00	10	36.91						
11	325.00	11	36.91						
12	325.00								
13	325.00								
14	325.00								
15	325.00								
16	325.00								

Sensor readback updates live from sbRIO  
Note: No sensors are connected to chassis at time of screen shot, hence 325 K value for Cerenox sensors

# Remote Web Interface – Configuration Page

The screenshot shows a web browser window with the URL `dsgsbrio2.jlab.org:8002/web/home.html`. The page title is "MSELV Chassis". There are two tabs: "Monitor" and "Configuration". The "Configuration" tab is active. A dropdown menu labeled "Chassis Select:" is set to "Torus Chassis 1". Below this is a table of sensor counts:

Sensor Counts				
Cernox	PT100	Load Cell	Strain Gauge	Hall Sensor
16	11	6	8	1

Below the table are three input fields for sbRIO configuration:

- sbRIO Hostname: `dsgsbrio2`
- sbRIO IP Address: `129.57.86.177`
- sbRIO Uptime [s]: `256`

A "Reboot" button is located below these fields.

Red callout boxes with arrows point to the following elements:

- Chassis configuration selector**: Points to the "Chassis Select:" dropdown menu.
- Sensor quantity for each sensor type**: Points to the sensor count table.
- sbRIO IP address and hostname**: Points to the "sbRIO IP Address" and "sbRIO Hostname" fields.
- sbRIO uptime**: Points to the "sbRIO Uptime [s]" field.
- "Soft Reboot" button to restart sbRIO program to implement configuration changes**: Points to the "Reboot" button.



# Remote Web Interface – Security

- Since MSELV chassis interface will be available through a web browser, page should be secured to prevent accidental changes to configurations
- Possible solutions
  - Standard HTML password method
  - NI web server configuration settings

# Sensor Flexibility – Input Ports

- Currently, chassis sensor ports are partitioned so sensors of certain types must be plugged into specific ports
- Want to be able to change sensor configurations in chassis on the fly

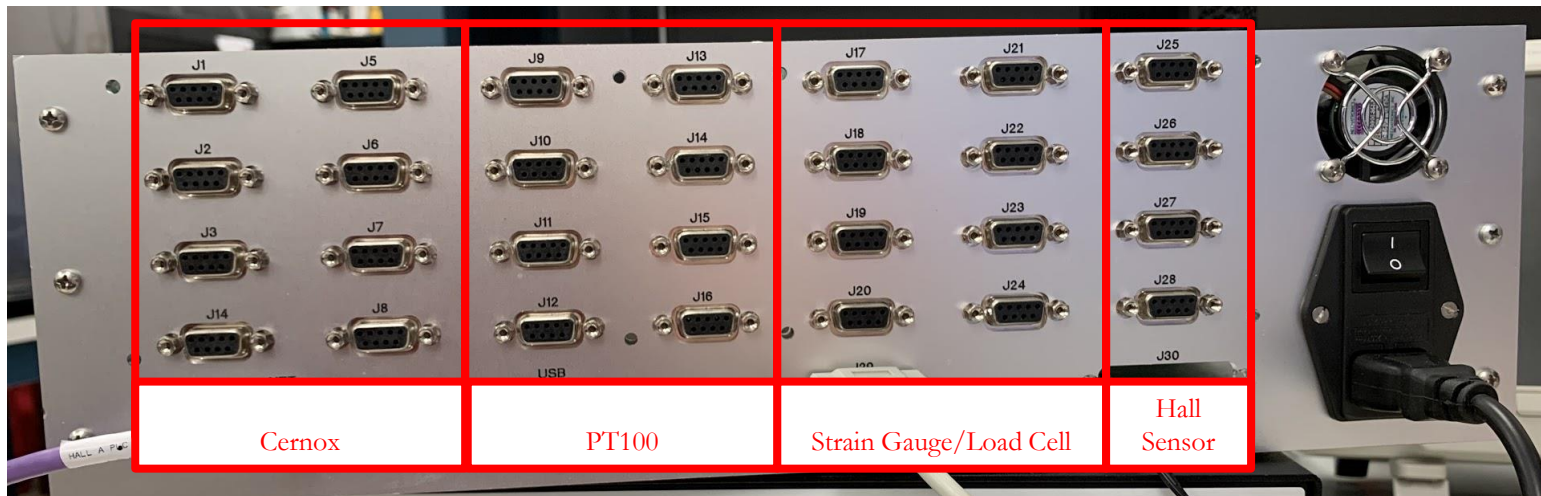

Rear panel of MSELV chassis showing sensor ports and what sensors they are programmed to read

# Sensor Flexibility – Sensor Configurations

- Currently, chassis configurations can only be changed by experts by changing hard-coded LabVIEW constants
- Researching how to allow user to select configuration through a user interface
  - Successfully able to implement configuration selection control on web interface to pick between LabVIEW constants
  - Investigating how to upload and store configurations as files on sbRIO

# Direct EPICS Communication

- sbRIO has built-in functionality to act as an EPICS server
- Direct communication to EPICS would allow MSELV chassis to be used in applications where there is no PLC
- Will be investigated after MSELV chassis is verified to work in Hall B with existing PLC controls system

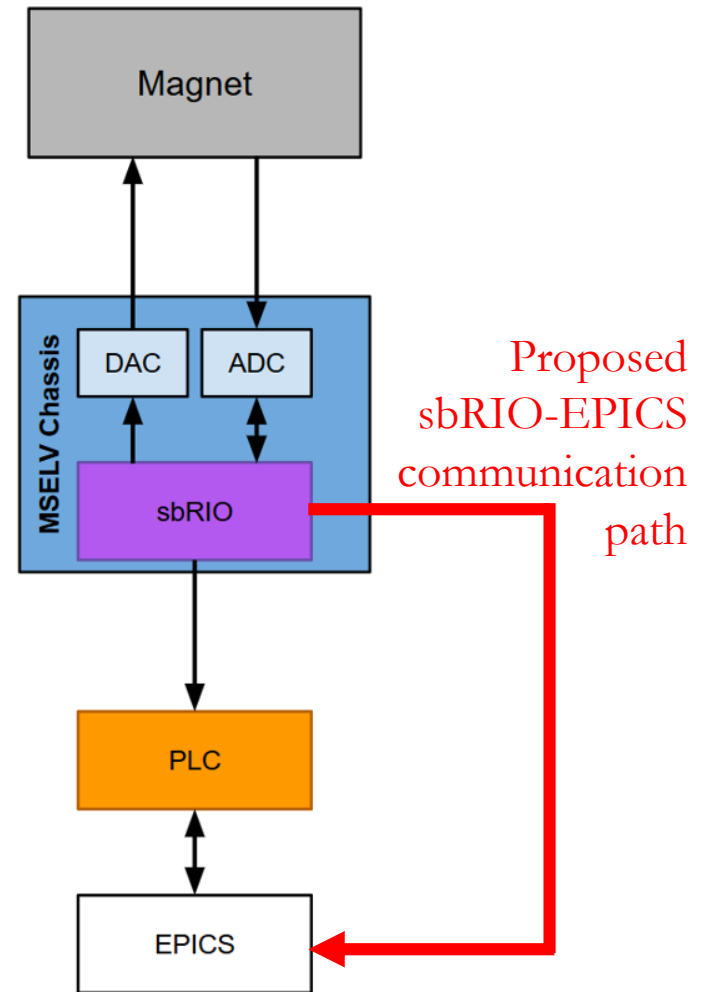

# Conclusion

- Further improvements to sbRIO-based MSELV chassis are under investigation
  - Goal is to make its LabVIEW program transparent to end user
- Proposed features
  - Increased sensor quantity
  - sbRIO Breakout RIO Mezzanine Card (RMC)
  - Remote web interface
  - Sensor flexibility
    - Input ports
    - Sensor configurations
  - Direct EPICS communication

**Thank You**

